

▼ Erdgeschoss

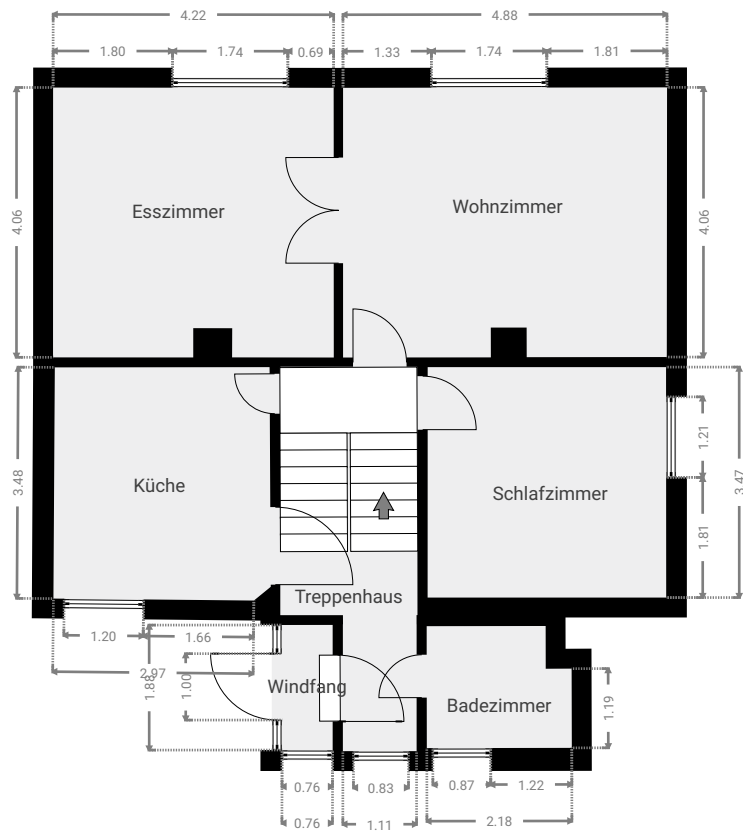

▼ **Badezimmer**  
Erdgeschoss

BREITE: 2.18 m · LÄNGE: 1.84 m · DECKENHÖHE: 2.76 m  
BEREICH: 3.75 m<sup>2</sup> · UMFANG: 8.03 m

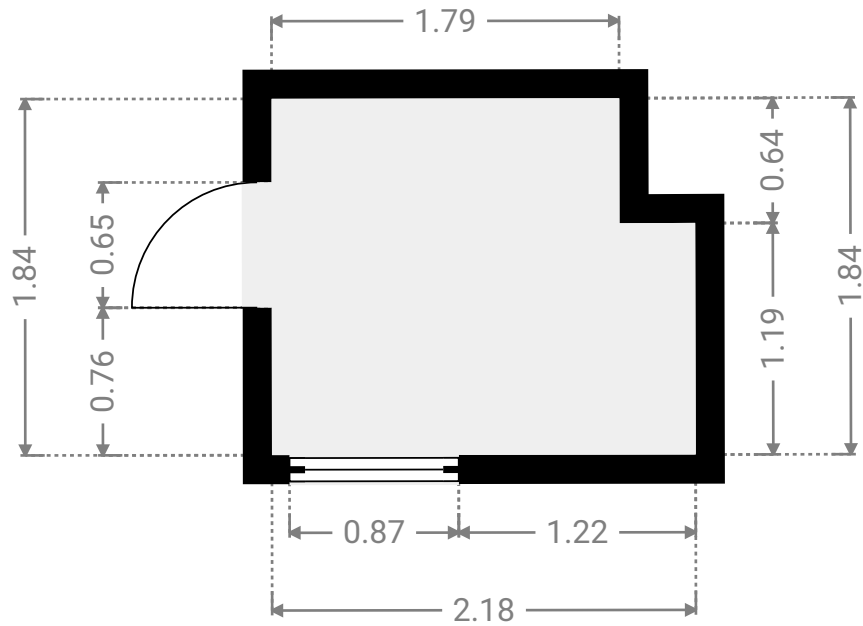
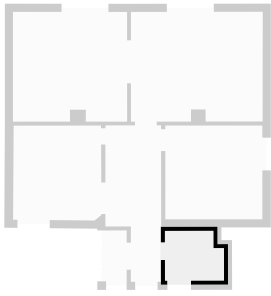

▼ **Eingangsbereich**  
Erdgeschoss

BREITE: 1.11 m · LÄNGE: 1.91 m · DECKENHÖHE: 2.76 m  
BEREICH: 2.12 m<sup>2</sup> · UMFANG: 6.04 m

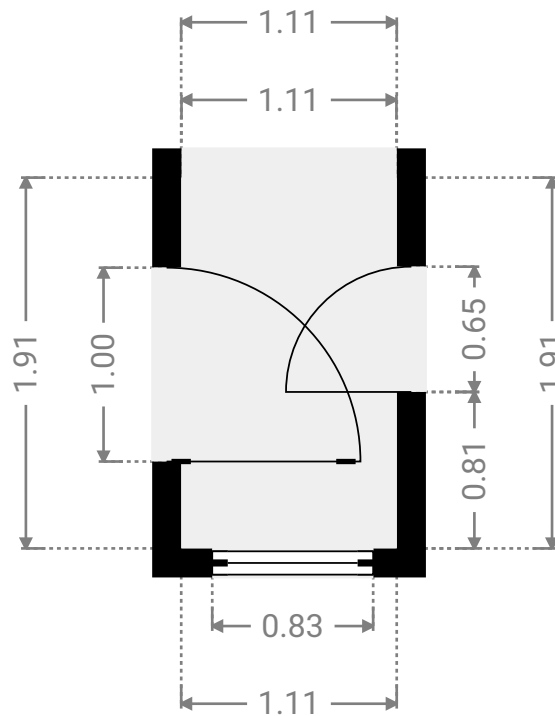
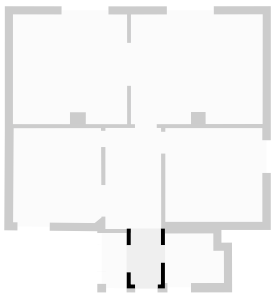

▼ **Esszimmer**  
Erdgeschoss

BREITE: 4.23 m • LÄNGE: 4.06 m • DECKENHÖHE: 2.76 m  
BEREICH: 16.90 m<sup>2</sup> • UMFANG: 17.45 m

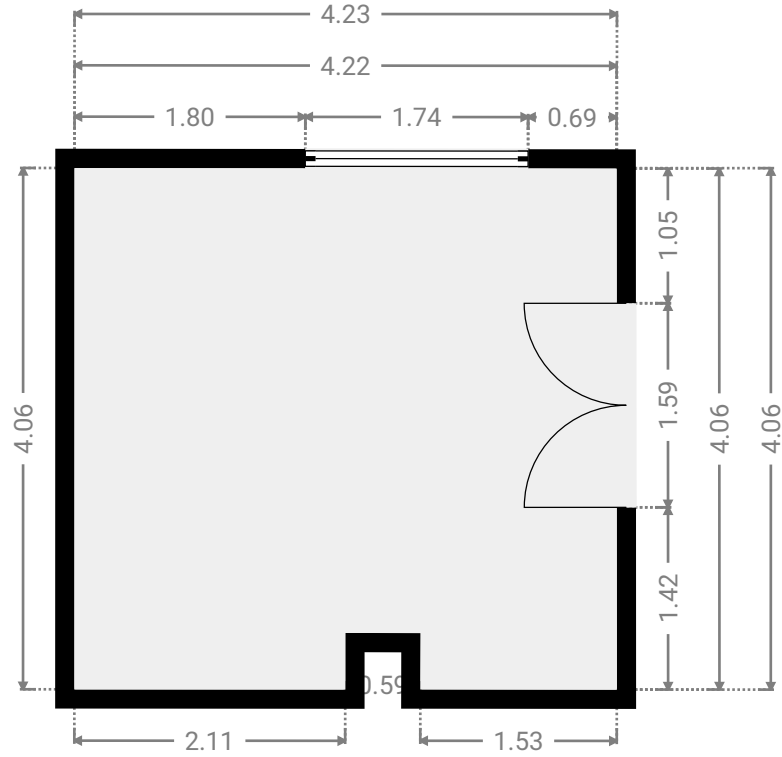
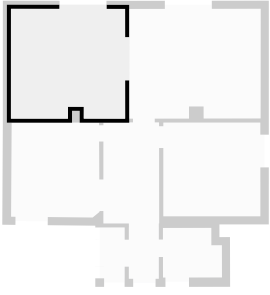

▼ **Küche**  
Erdgeschoss

BREITE: 3.27 m • LÄNGE: 3.52 m • DECKENHÖHE: 2.76 m  
BEREICH: 11.36 m<sup>2</sup> • UMFANG: 13.37 m

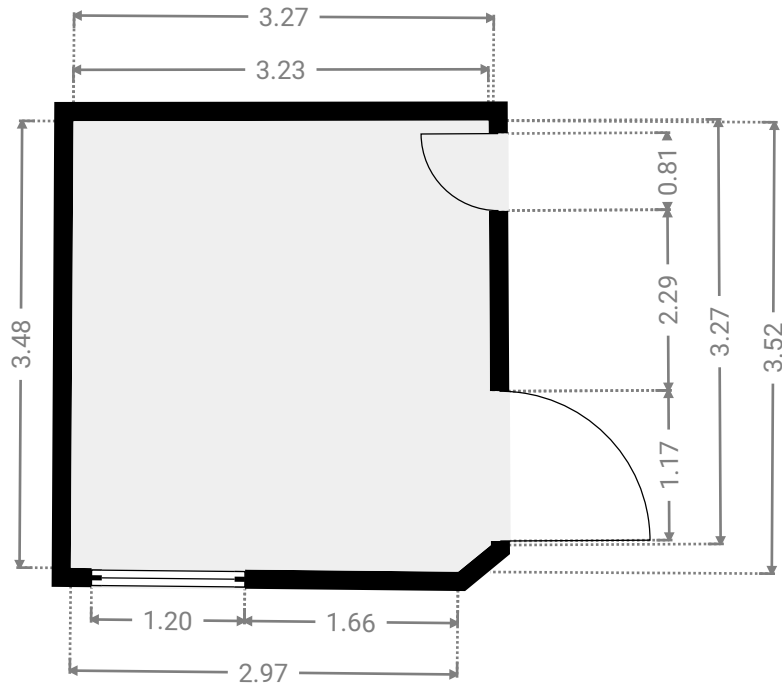
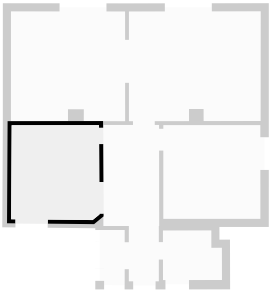

▼ **Schlafzimmer**  
Erdgeschoss

BREITE: 3.59 m · LÄNGE: 3.47 m · DECKENHÖHE: 2.76 m  
BEREICH: 12.46 m<sup>2</sup> · UMFANG: 14.12 m

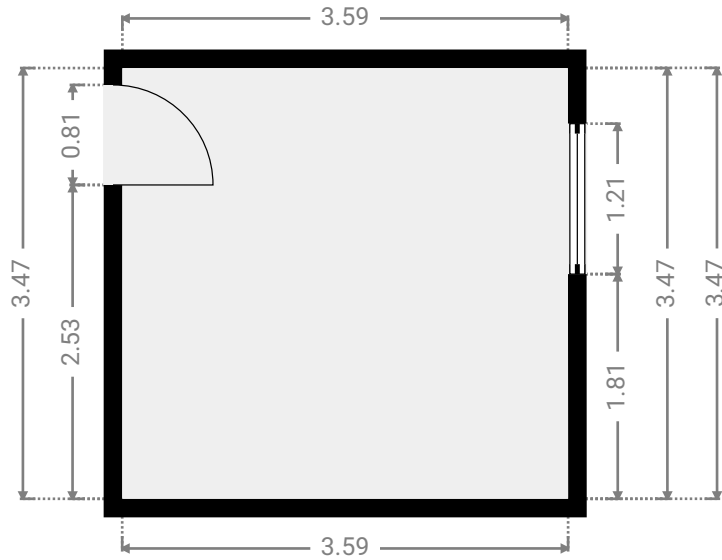
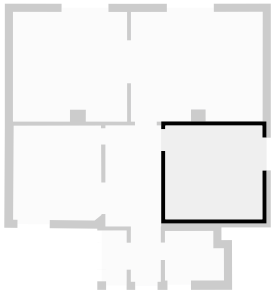

▼ **Treppenhaus**  
Erdgeschoss

BREITE: 2.06 m · LÄNGE: 3.74 m · DECKENHÖHE: 2.76 m  
BEREICH: 7.71 m<sup>2</sup> · UMFANG: 11.61 m

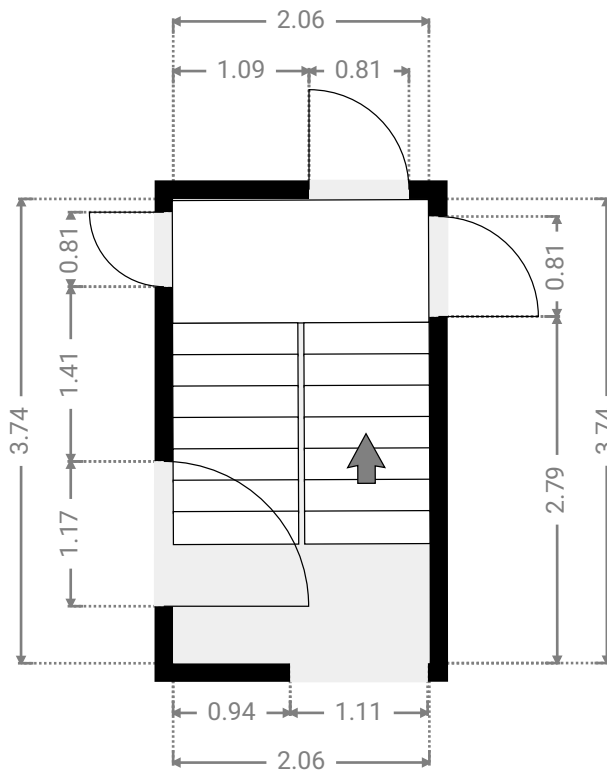
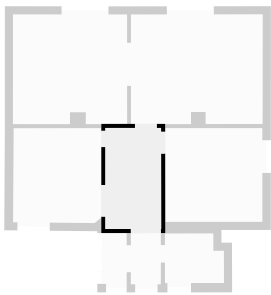

▼ **Windfang**  
Erdgeschoss

BREITE: 0.76 m • LÄNGE: 1.88 m • DECKENHÖHE: 2.76 m  
BEREICH: 1.43 m<sup>2</sup> • UMFANG: 5.29 m

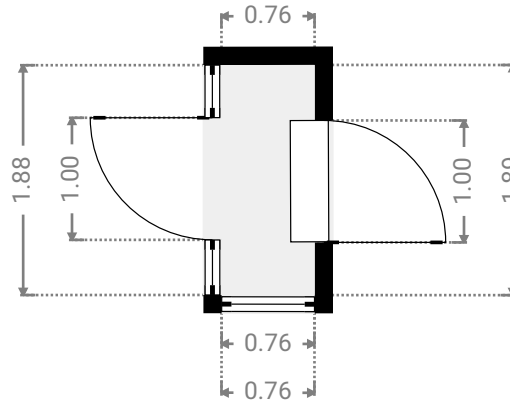
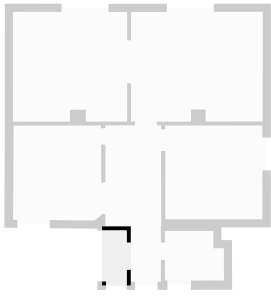

▼ **Wohnzimmer**  
Erdgeschoss

BREITE: 4.88 m • LÄNGE: 4.06 m • DECKENHÖHE: 2.76 m  
BEREICH: 19.56 m<sup>2</sup> • UMFANG: 18.77 m

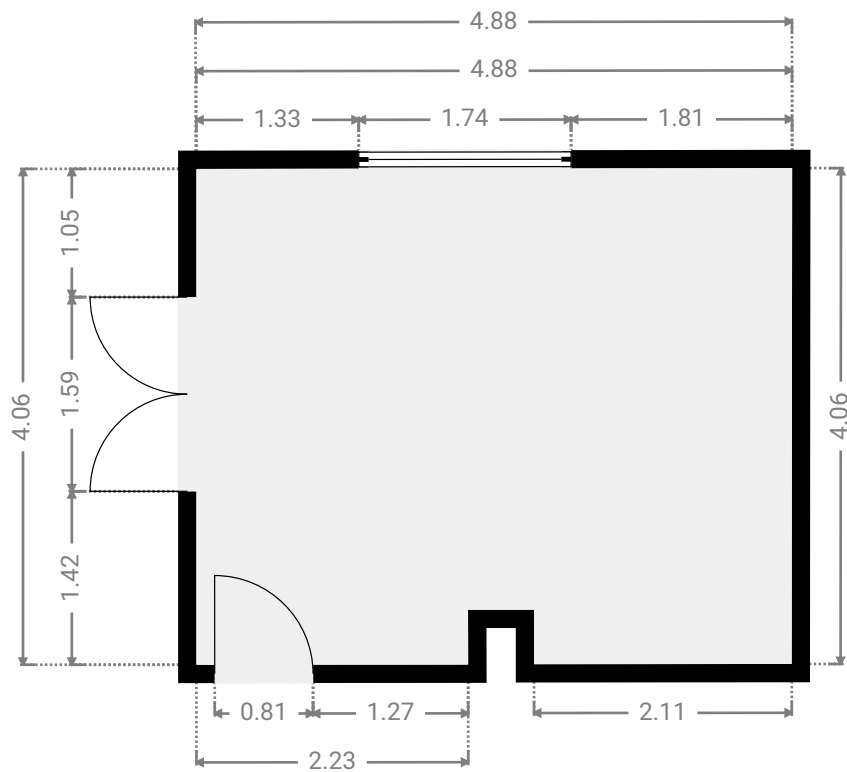
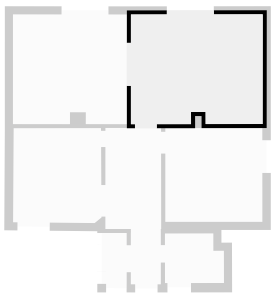

▼ 1. Stock

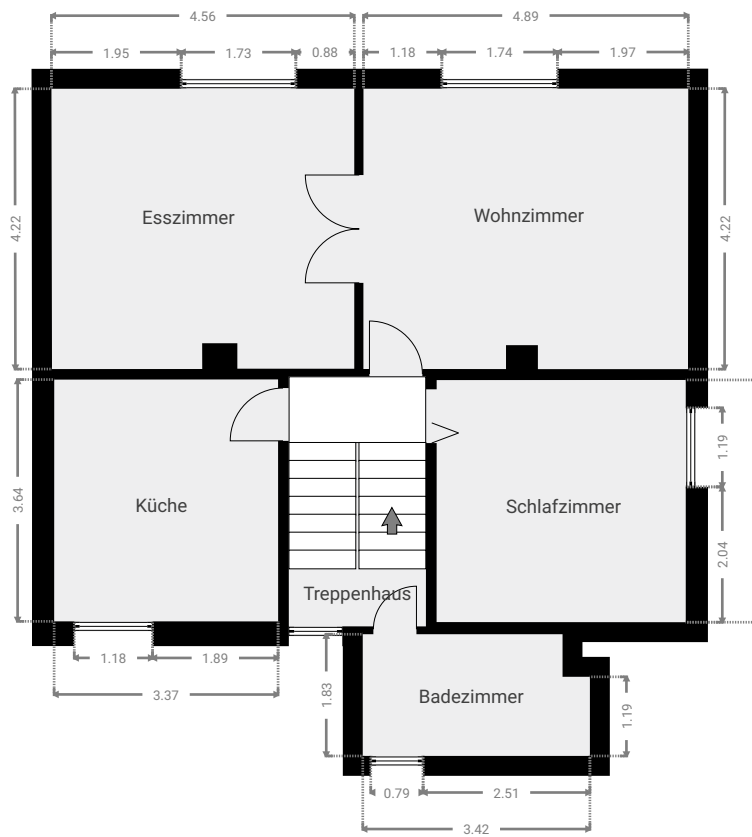

▼ **Badezimmer**  
1. Stock

BREITE: 3.42 m • LÄNGE: 1.83 m • DECKENHÖHE: 2.64 m  
BEREICH: 6.00 m<sup>2</sup> • UMFANG: 10.50 m

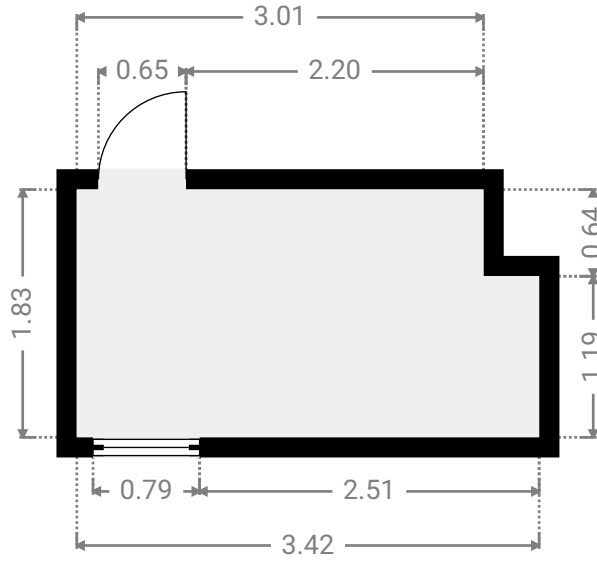
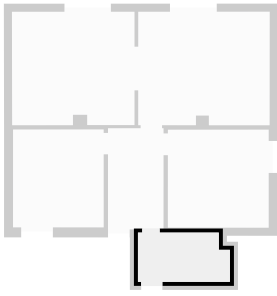

▼ **Esszimmer**  
1. Stock

BREITE: 4.56 m • LÄNGE: 4.22 m  
BEREICH: 19.01 m<sup>2</sup> • UMFANG: 18.32 m

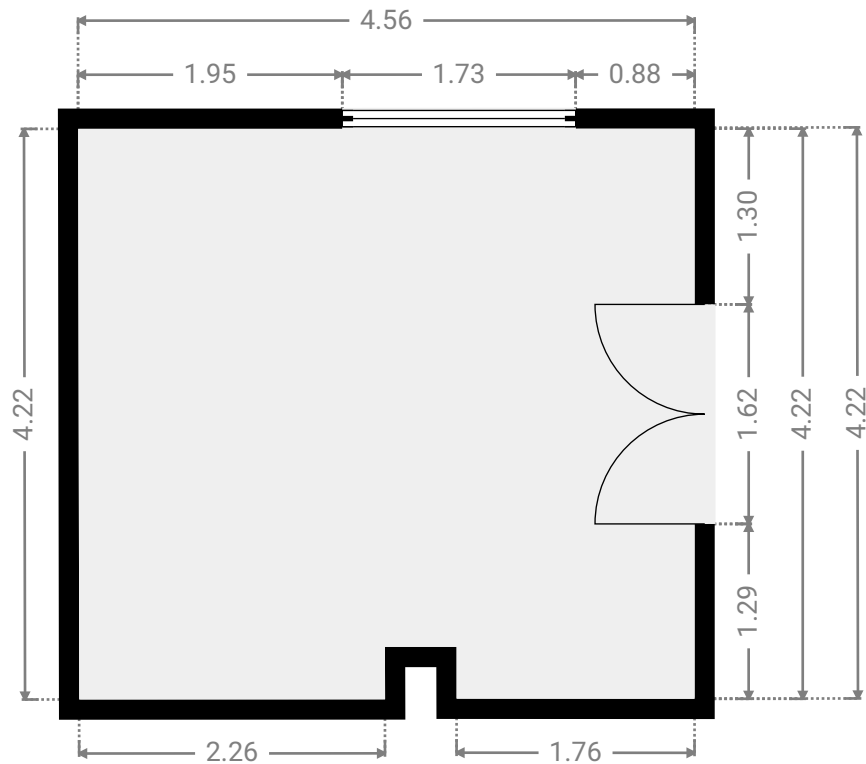
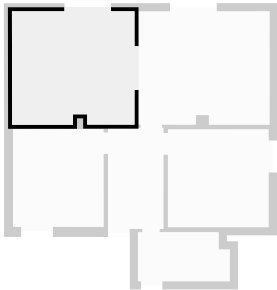

▼ **Küche**  
1. Stock

BREITE: 3.37 m • LÄNGE: 3.64 m  
BEREICH: 12.28 m<sup>2</sup> • UMFANG: 14.03 m

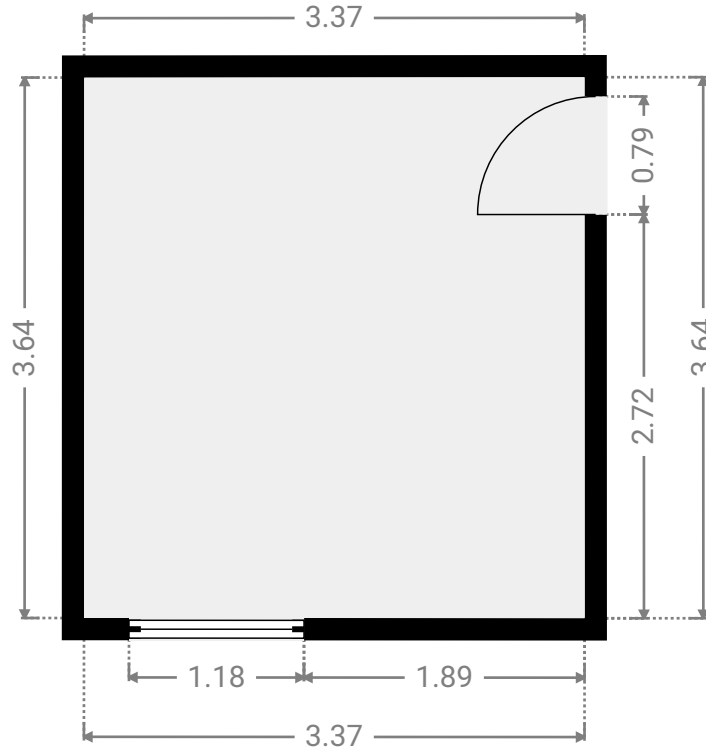
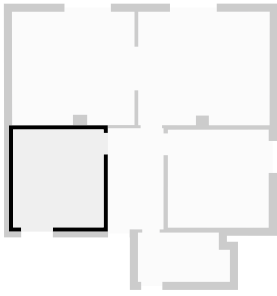

▼ **Schlafzimmer**  
1. Stock

BREITE: 3.75 m • LÄNGE: 3.65 m  
BEREICH: 13.67 m<sup>2</sup> • UMFANG: 14.79 m

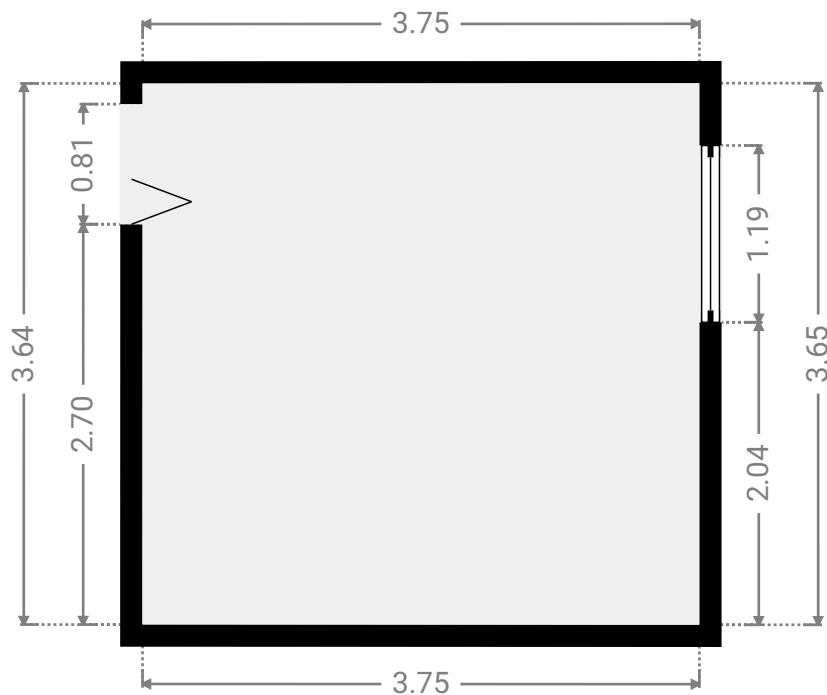
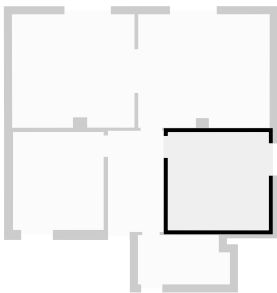

▼ **Treppenhaus**  
1. Stock

BREITE: 2.07 m · LÄNGE: 3.76 m  
BEREICH: 7.77 m<sup>2</sup> · UMFANG: 11.66 m

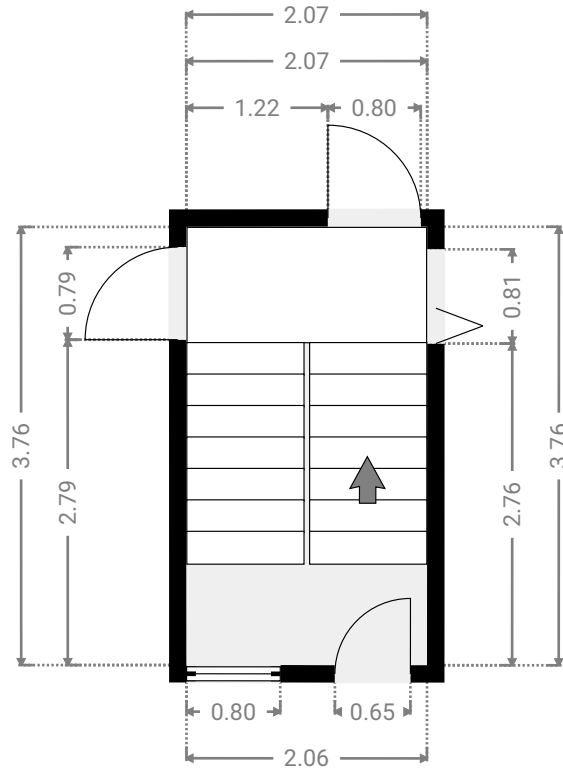
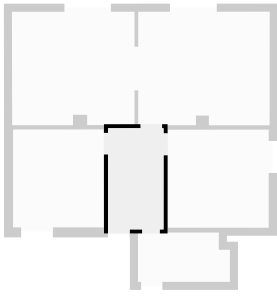

▼ **Wohnzimmer**  
1. Stock

BREITE: 4.89 m · LÄNGE: 4.22 m  
BEREICH: 20.47 m<sup>2</sup> · UMFANG: 18.94 m

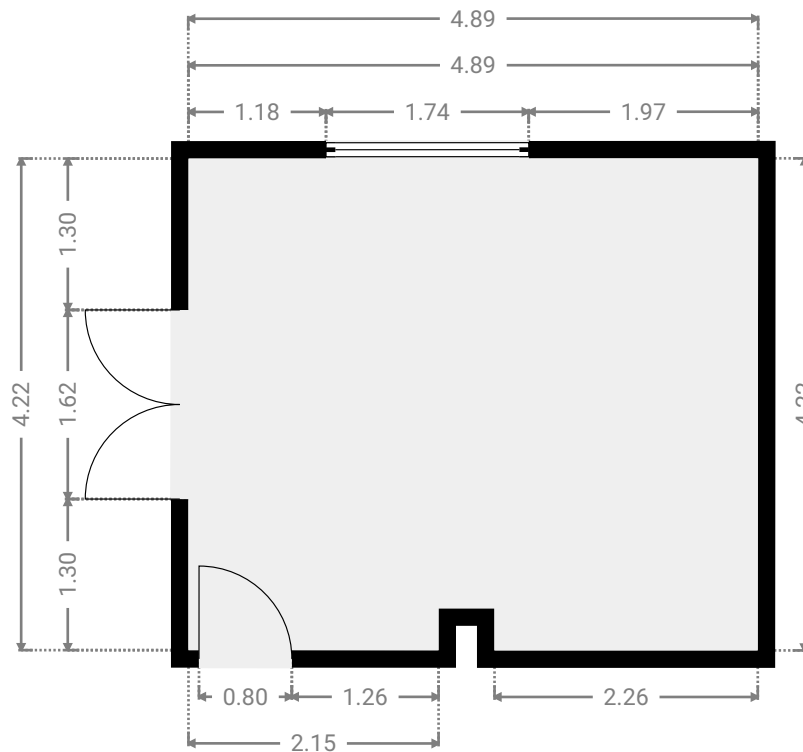
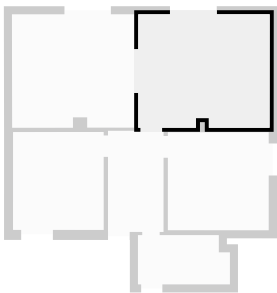

## ▼ Dachgeschoss

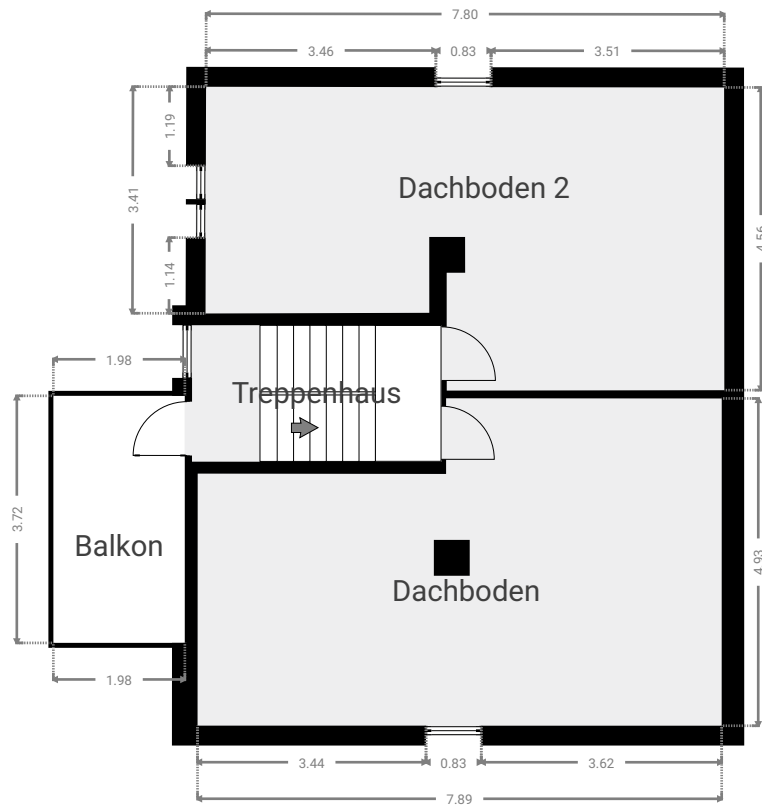

▼ **Dachboden**  
Dachgeschoss

BREITE: 4.93 m • LÄNGE: 7.89 m • DECKENHÖHE: 2.35 m  
BEREICH: 34.65 m<sup>2</sup> • UMFANG: 25.65 m

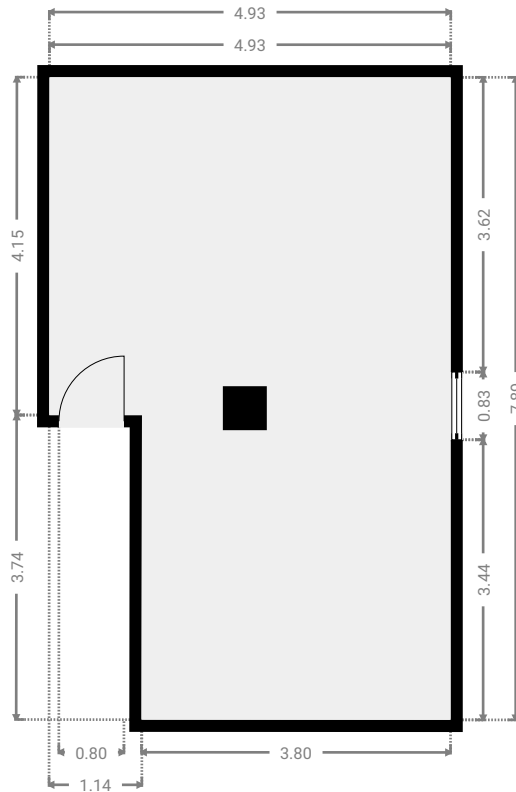
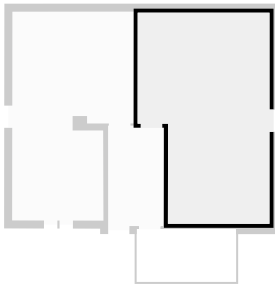

▼ **Dachboden 2**  
Dachgeschoss

BREITE: 4.58 m • LÄNGE: 7.81 m • DECKENHÖHE: 2.35 m  
BEREICH: 30.97 m<sup>2</sup> • UMFANG: 27.59 m

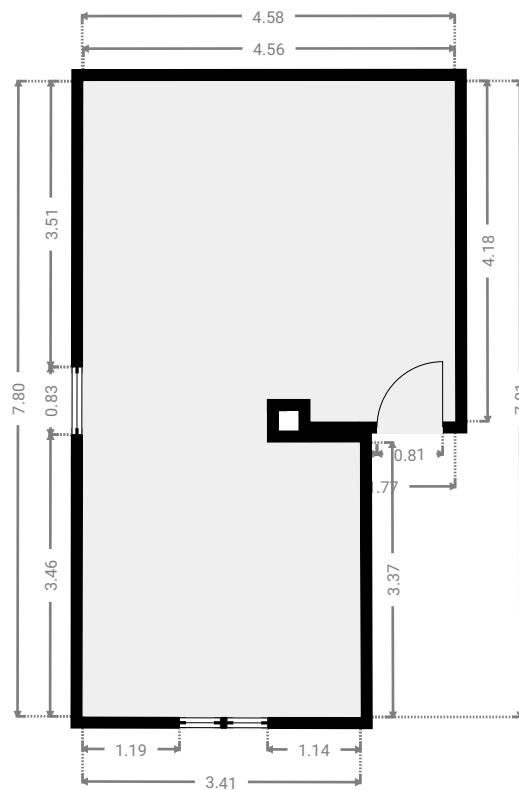
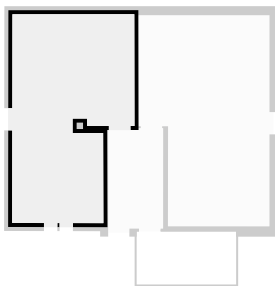

▼ **Treppenhaus**  
Dachgeschoss

BREITE: 2.06 m • LÄNGE: 3.76 m • DECKENHÖHE: 2.35 m  
BEREICH: 7.73 m<sup>2</sup> • UMFANG: 11.62 m

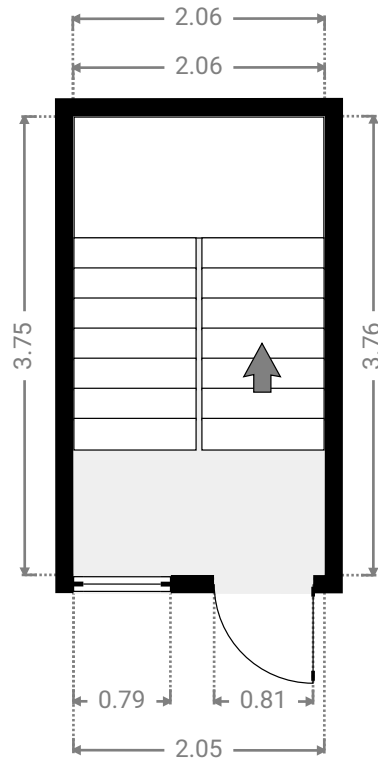
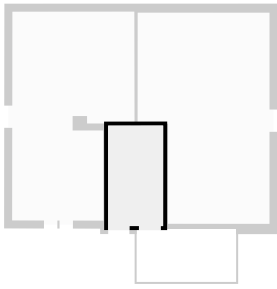

▼ **Balkon**  
Dachgeschoss

BREITE: 3.72 m • LÄNGE: 1.98 m • DECKENHÖHE: 2.35 m  
BEREICH: 7.37 m<sup>2</sup> • UMFANG: 11.40 m

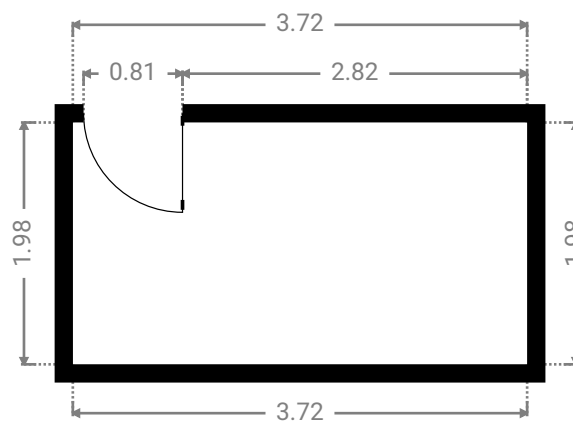
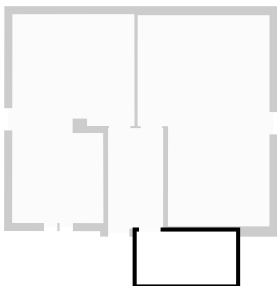



▼ **Flur**  
1. Untergeschoss

BREITE: 2.09 m • LÄNGE: 3.76 m • DECKENHÖHE: 2.32 m  
BEREICH: 7.85 m<sup>2</sup> • UMFANG: 11.70 m

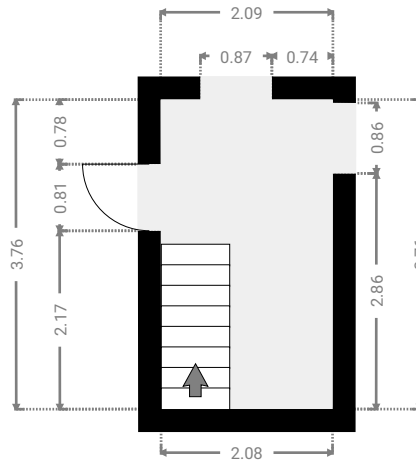
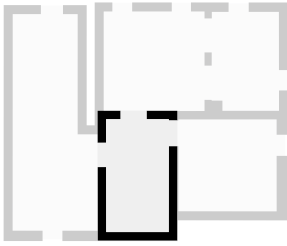

▼ **Heizungsraum**  
1. Untergeschoss

BREITE: 2.84 m • LÄNGE: 7.22 m • DECKENHÖHE: 2.32 m  
BEREICH: 17.77 m<sup>2</sup> • UMFANG: 20.10 m

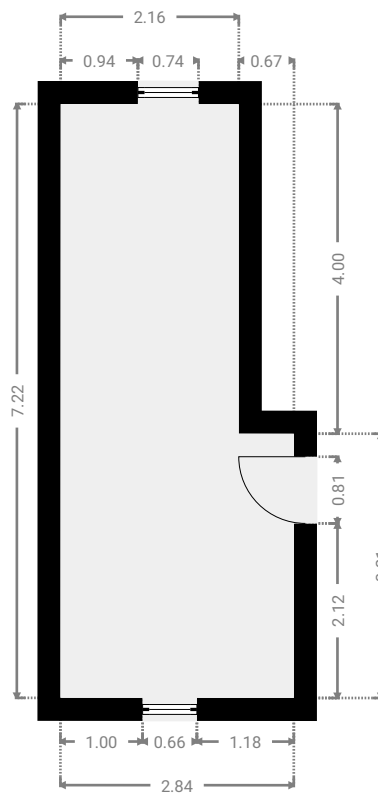
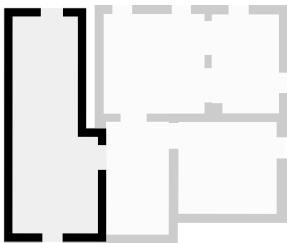

▼ Keller  
1. Untergeschoss

BREITE: 3.27 m • LÄNGE: 3.06 m • DECKENHÖHE: 2.32 m  
BEREICH: 10.02 m<sup>2</sup> • UMFANG: 12.67 m

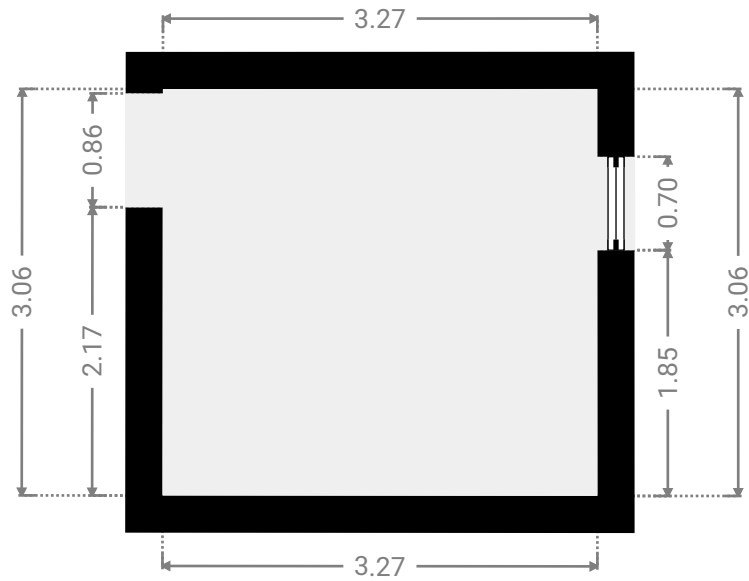
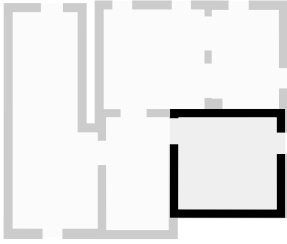

▼ Keller 2  
1. Untergeschoss

BREITE: 3.36 m • LÄNGE: 3.32 m • DECKENHÖHE: 2.32 m  
BEREICH: 11.15 m<sup>2</sup> • UMFANG: 13.36 m

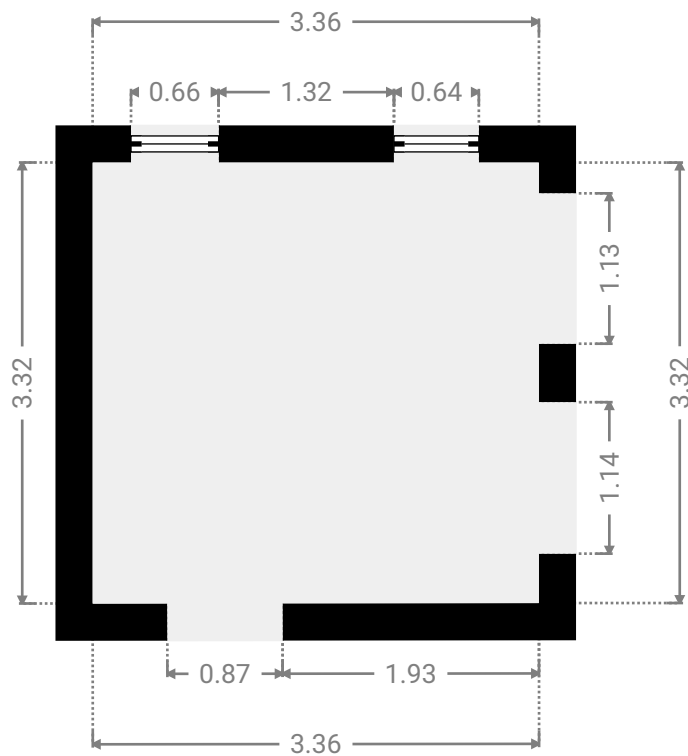
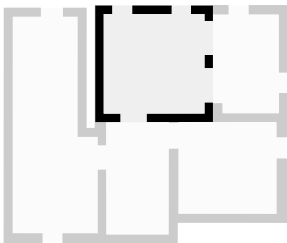

▼ Keller 3  
1. Untergeschoss

BREITE: 2.24 m • LÄNGE: 3.30 m • DECKENHÖHE: 2.32 m  
BEREICH: 7.26 m<sup>2</sup> • UMFANG: 11.07 m

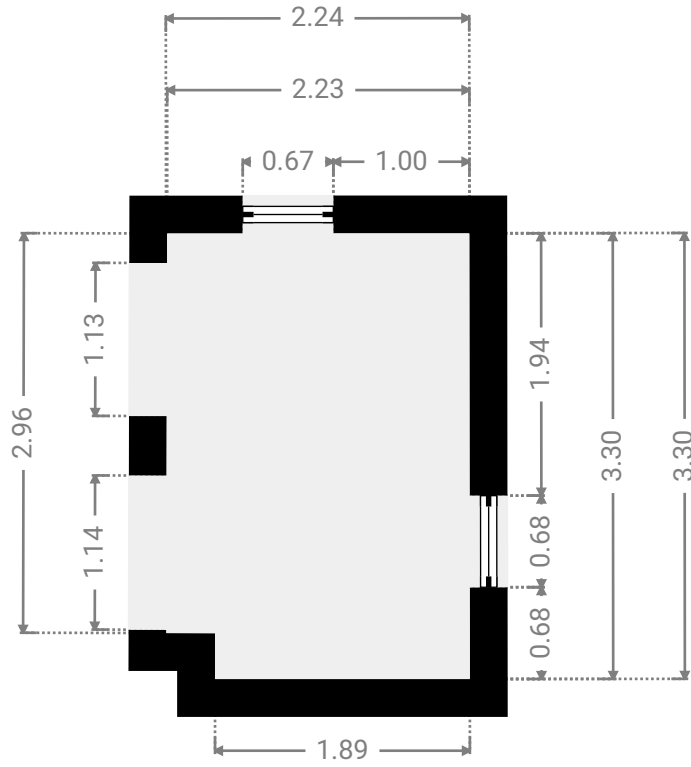
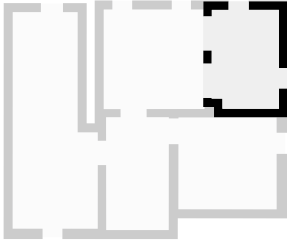

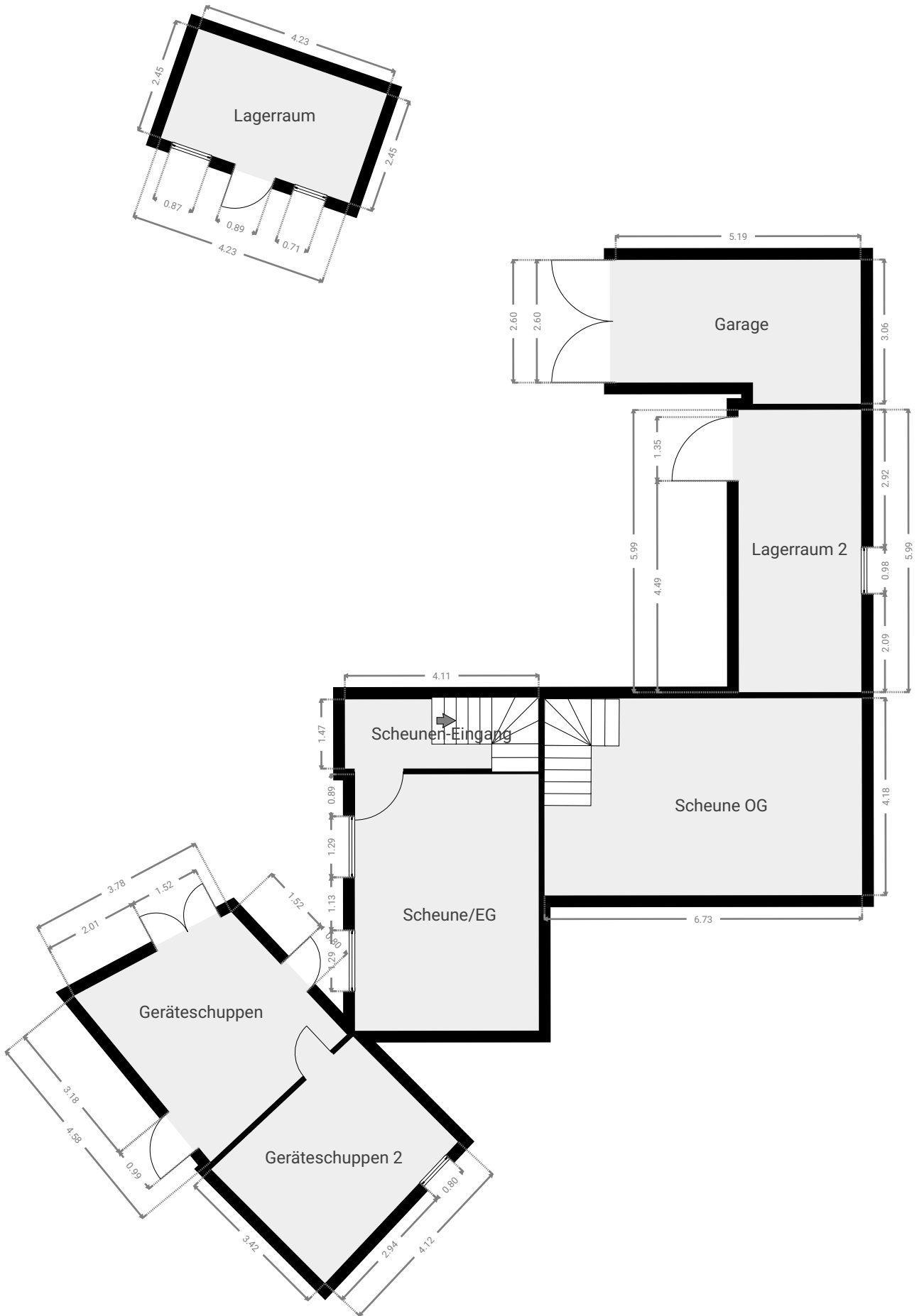

▼ Garage  
Hof

BREITE: 3.06 m • LÄNGE: 5.19 m • DECKENHÖHE: 2.35 m  
BEREICH: 14.54 m<sup>2</sup> • UMFANG: 16.49 m

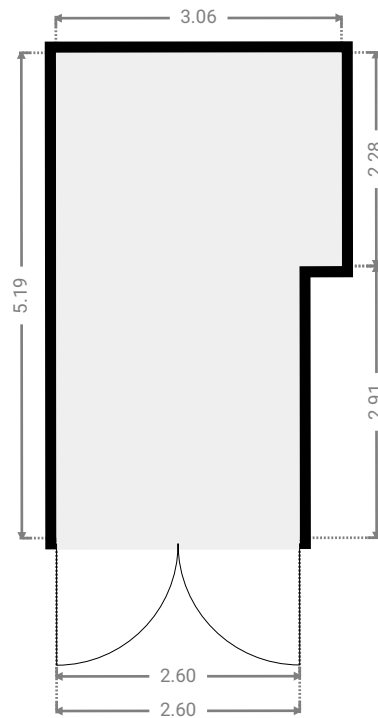
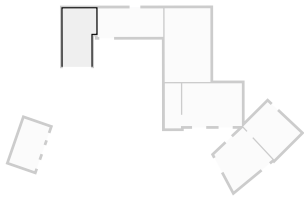

▼ Geräteschuppen  
Hof

BREITE: 4.57 m • LÄNGE: 3.96 m  
BEREICH: 15.52 m<sup>2</sup> • UMFANG: 15.87 m

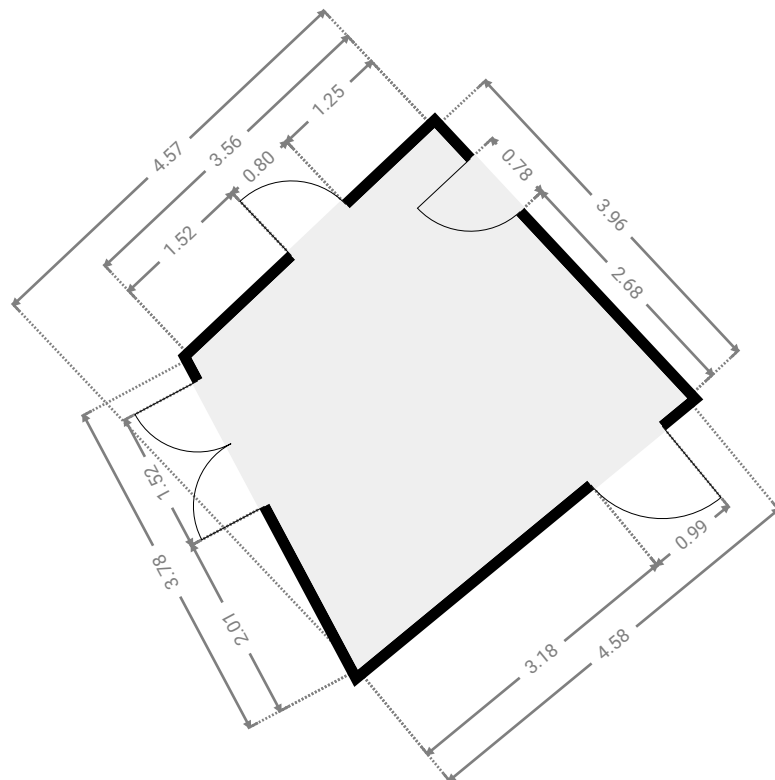
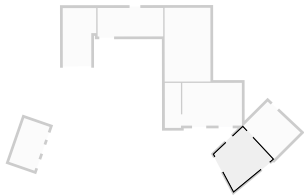

▼ **Geräteschuppen 2**  
Hof

BREITE: 3.42 m • LÄNGE: 4.12 m  
BEREICH: 13.52 m<sup>2</sup> • UMFANG: 14.81 m

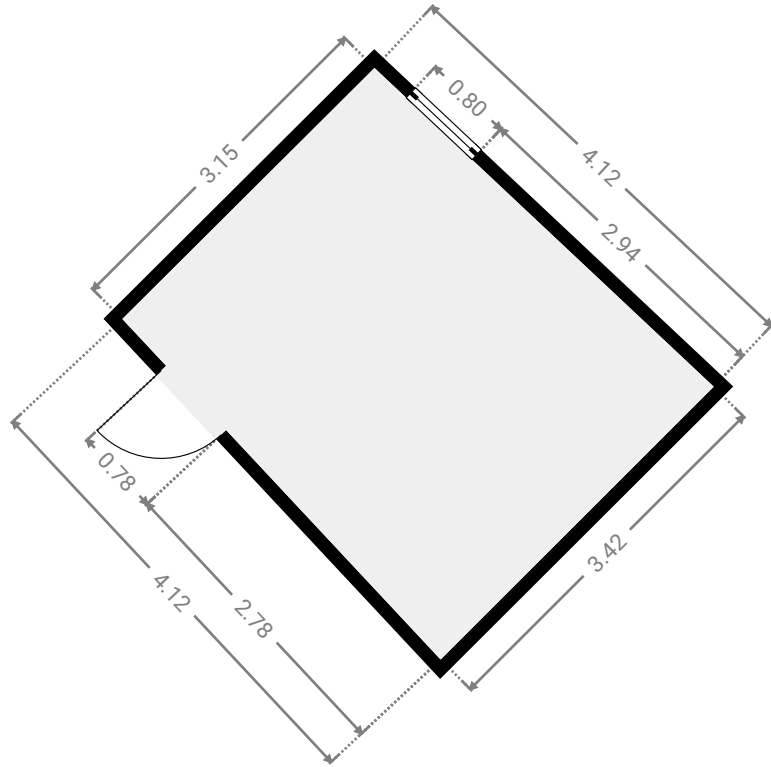
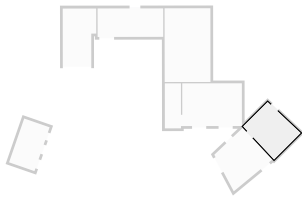

▼ **Lagerraum**  
Hof

BREITE: 2.45 m • LÄNGE: 4.23 m  
BEREICH: 10.36 m<sup>2</sup> • UMFANG: 13.36 m

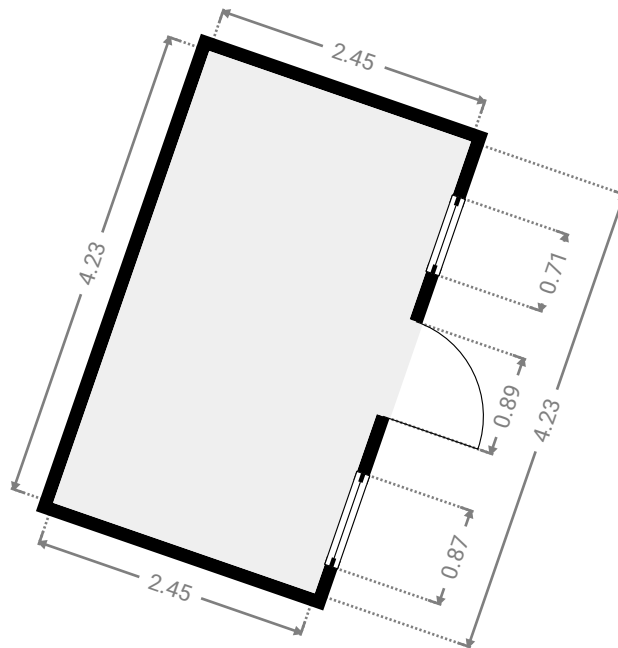
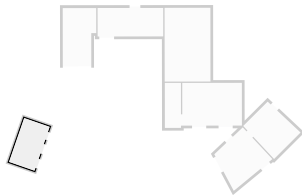

▼ **Lagerraum 2**  
Hof

BREITE: 5.99 m · LÄNGE: 2.60 m  
BEREICH: 15.56 m<sup>2</sup> · UMFANG: 17.18 m

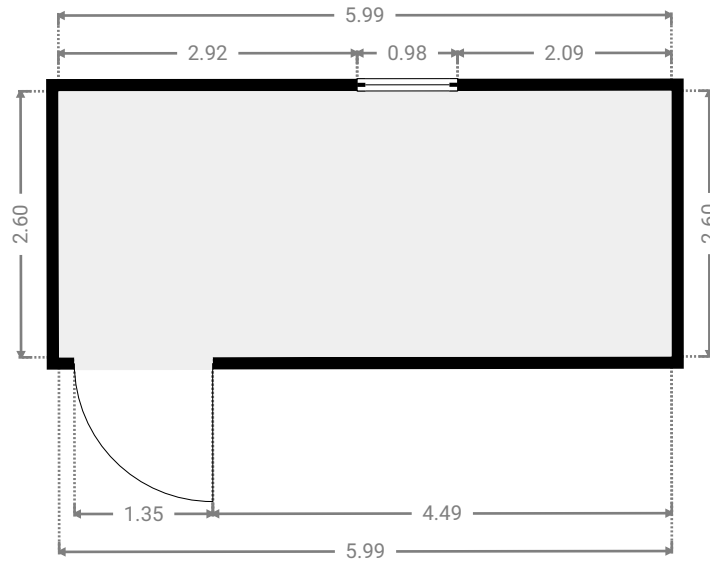
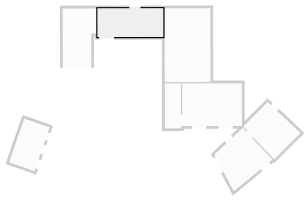

▼ **Scheune OG**  
Hof

BREITE: 4.18 m · LÄNGE: 6.73 m  
BEREICH: 28.12 m<sup>2</sup> · UMFANG: 21.82 m

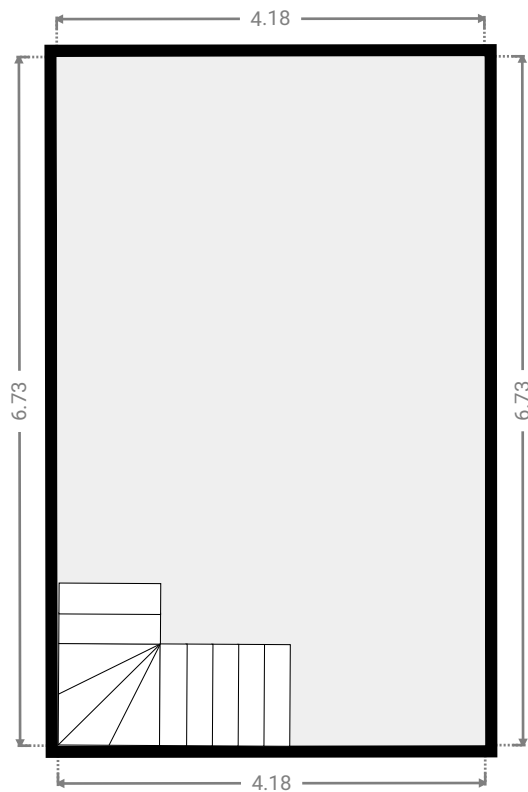
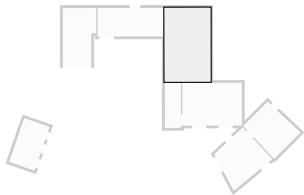

▼ **Scheune/EG**  
Hof

BREITE: 5.44 m • LÄNGE: 3.90 m  
BEREICH: 21.22 m<sup>2</sup> • UMFANG: 18.68 m

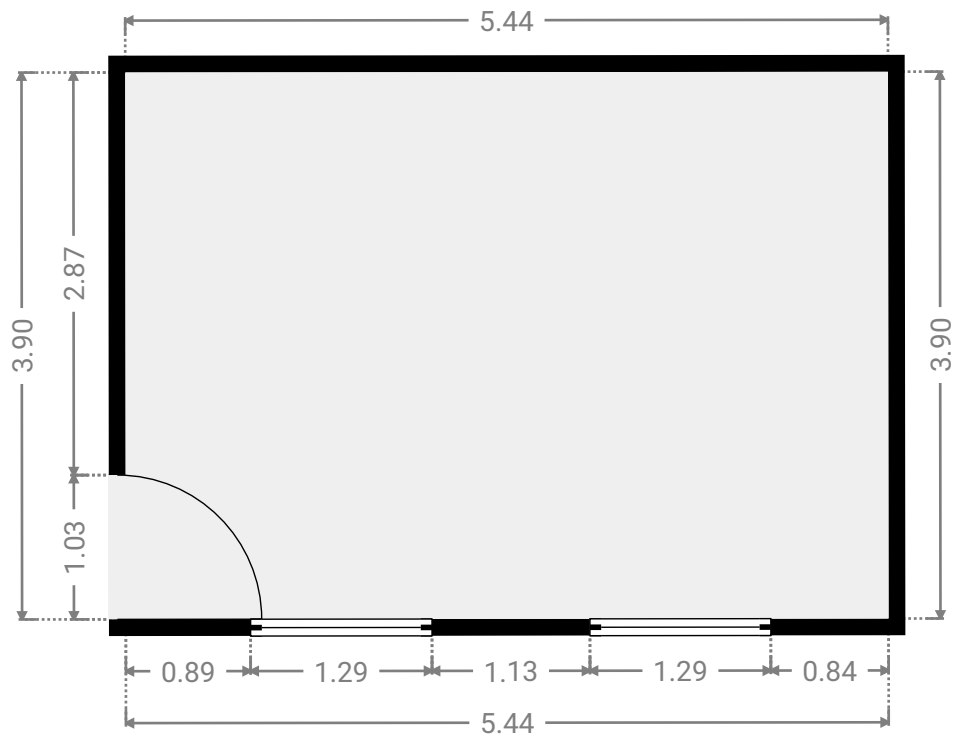
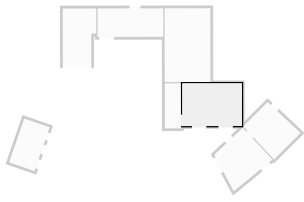

▼ **Scheunen-Eingang**  
Hof

BREITE: 1.47 m • LÄNGE: 4.11 m  
BEREICH: 6.04 m<sup>2</sup> • UMFANG: 11.16 m

